

**Product Details**

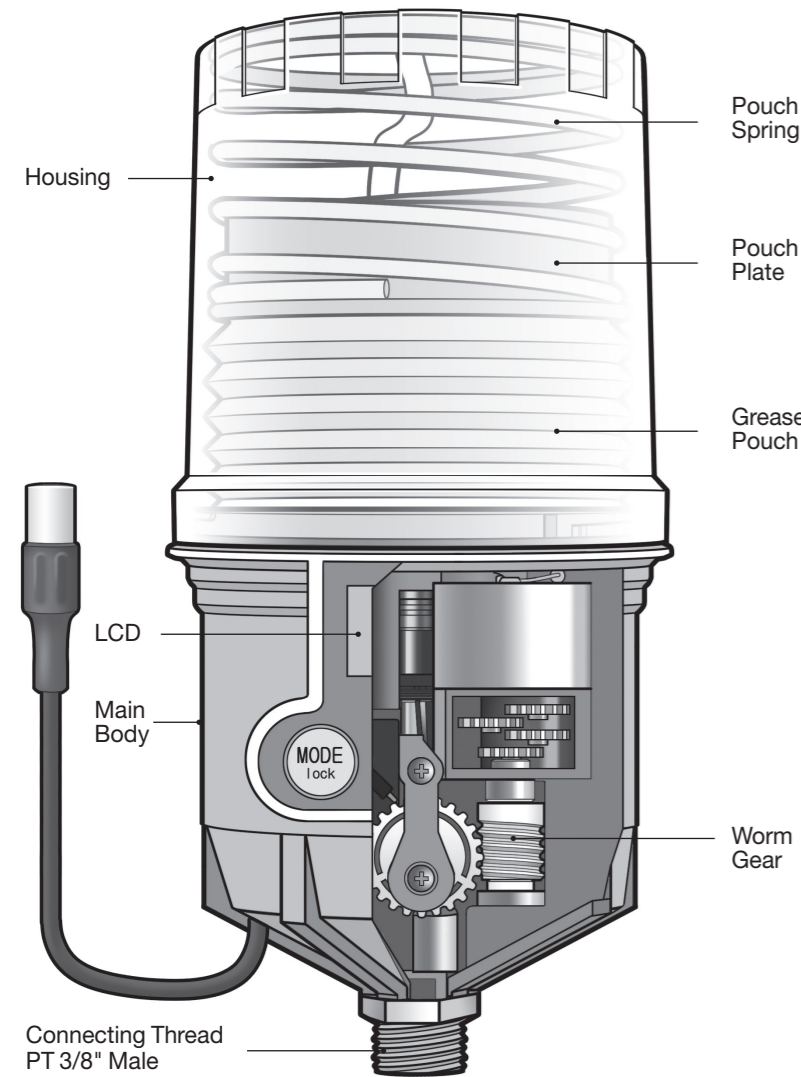

**Installation Guidelines**

\* All parts should be assembled tightly with PTFE tape.

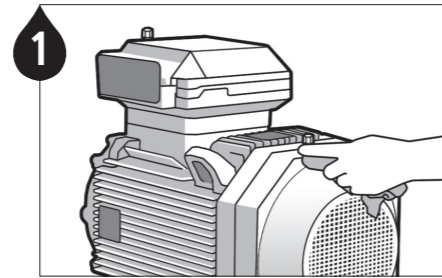

1 Remove contaminants around the lube point.

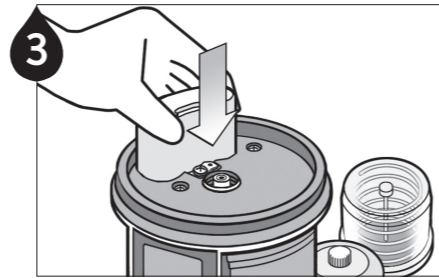

3 Insert battery pack.

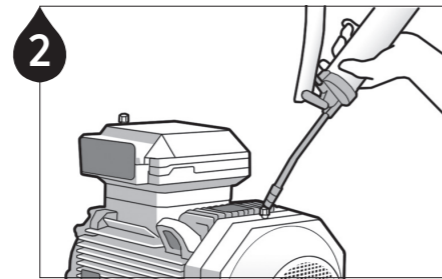

2 Ensure a clear passage using a manual grease gun. **Note 1** Remove any hardened grease by purging the lube point with a manual grease gun. **Note 2** The grease in the equipment and the grease contained in the unit should be the same or compatible.

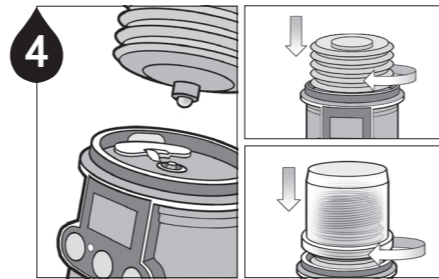

4 Purge the grease pouch until grease comes out of the tip. Carefully screw the grease pouch in by turning clockwise. Do not over tighten. Refit the top housing on the unit and turn clockwise until it clicks.

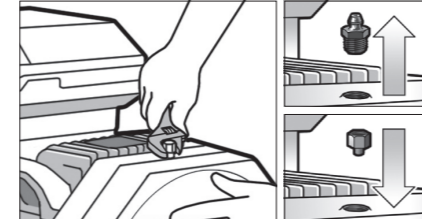

5 Remove the grease nipple and install appropriate adaptors.

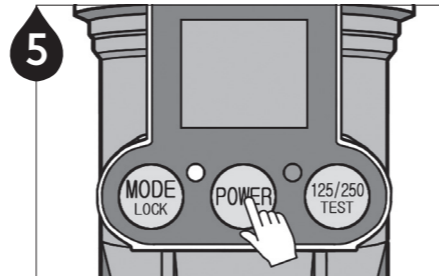

6 Press the POWER button for 2 seconds to turn the unit on.

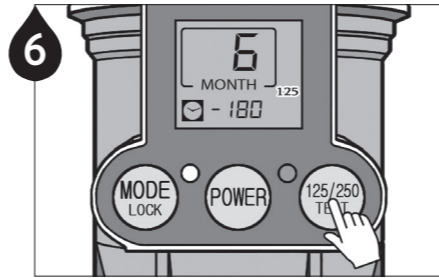

7 Select the appropriate grease pouch capacity by pressing the 125/250/TEST button. (Omit this process for 60ml and 500ml)

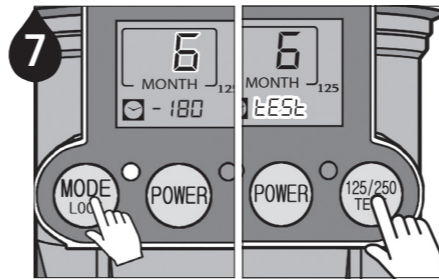

8 Press the MODE button to select dispensing period and hold the TEST button for 2 seconds to run a test cycle.

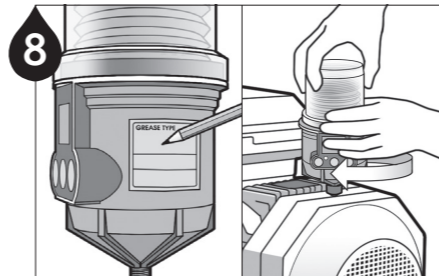

9 Note the installation date and the scheduled completion date of lube cycle on the lubricator using the label provided in the Service Pack for maintenance purposes. Install the unit on the lube point.

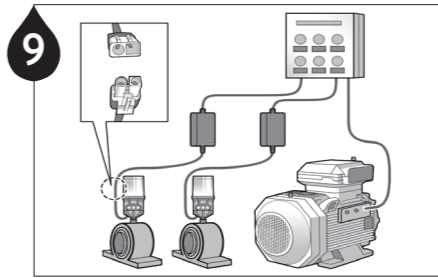

10 Connect VAC Adaptor/VDC Converter to the control panel. Connect the lubricator's power cable to VAC Adaptor/VDC Converter.

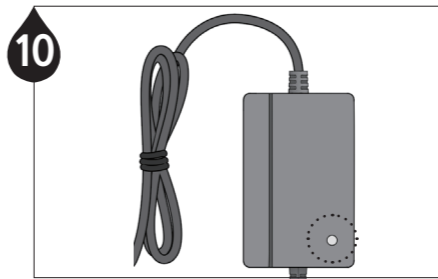

11 Check that the red LED of the VAC Adaptor/VDC Converter turns on when the control panel powers on.

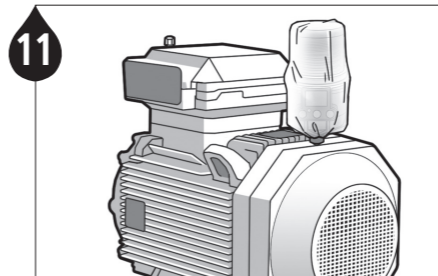

12 Install the dust cover over the lubricator for added protection.

**Troubleshooting Guidelines**

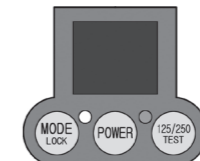

**Error** : Blank LCD screen  
**Possible Cause** : CPU electrical malfunction or battery problem  
**Solution** : Replace battery pack or press reset button to restart the lubricator. If the problem persists, contact your supplier.

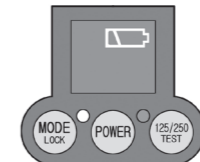

**Error** : Low Battery Indication  
**Possible Cause** : Rapid power consumption due to improper storage or harsh operating conditions (temperature, humidity, or high backpressure).  
**Solution** : Replace battery pack. Store the battery pack in cool, dry place and choose proper battery type for application.

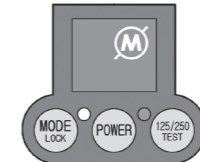

**Error** : Excessive Backpressure Indication  
**Possible Cause** : Excessive backpressure due to hardened grease, over-lubrication, ruptured lube line, long distance remote installation, etc.  
**Solution** : Purge grease into the lube point using a clean manual grease gun to eliminate possible hardened grease that may be causing an obstruction. This will alleviate excessive backpressure. Reduce lube line length if possible.

**Wiring Instructions**

**Warning.** Power off the equipment before wiring.

Select appropriate VAC Adaptor/VDC Converter needed for your application.

**Wiring Options**

- Control Panel
- Other Terminal

**VDC Wiring**

Connect in corresponding polarity (+) to (+) and (-) to (-) for DC powered units.

**VAC Wiring**

Wires can be connected in any polarity and does not need to match (+) to (+) and (-) to (-).

**Note**

Product warranty will be null and void if units are incorrectly wired. Installation by an electrician is recommended.

**Safety Instructions**

Avoid installing in the following places to ensure safety and reliability of VAC Adaptor/VDC Converter.

- High vibration areas
- Wet areas
- Where volatile and flammable substances are present
- Areas where moisture and fire can be easily reached
- Places with poor ventilation and high ambient temperatures

## Button Operation

### Dispensing Period

Press to set dispensing period  
 60ml : 1-12 month  
 125/250ml : 1, 2, 3, 6, 12 month & 15 days (H)  
 500ml : 1, 2, 4, 6, 12, 18, 24 month & 15 days (H)

**MODE LOCK**

Automatic Lock Out Mode  
 Press for 2 seconds to unlock (🔒)

**POWER**

Power **ON/OFF**  
 Press for 2 seconds to power unit on or off

### For 60ml / 500ml Unit Only

**TEST Mode**  
 ON : Press for 2 seconds  
 OFF : Short press of button  
 (will stop after completion of ongoing cycle)

**TEST**

### For 125ml / 250ml Unit Only

**Grease Capacity**  
 Press to select 125ml or 250ml  
**TEST Mode**  
 ON : Press for 2 seconds  
 OFF : Short press of button  
 (will stop after completion of ongoing cycle)

**125/250 TEST**

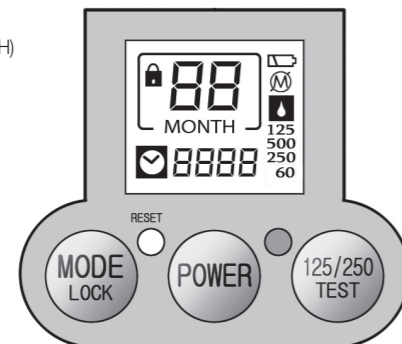

**RESET**

Reset to default setting when the unit malfunctions and/or after changing the Service Pack

## LCD Display

**6**  
 MONTH  
 Dispensing period setting

**CH03**  
 Number of days operation has been on hold due to excessive backpressure

**- 180**  
 Remaining dispensing days

Low battery power

Automatic Lock Out mode

Operation on hold due to excessive backpressure

**125/250**  
**60 or 500**  
 Grease pouch capacity

Dispensing period has completed

**TEST** TEST mode

LED blinks when battery is low, excessive backpressure exists, or dispensing period has completed

**503**  
 Number of days since dispensing period has completed  
 (🔒 and 📅 will also display)

ISO9001/14001 CE

## Mounting Methods

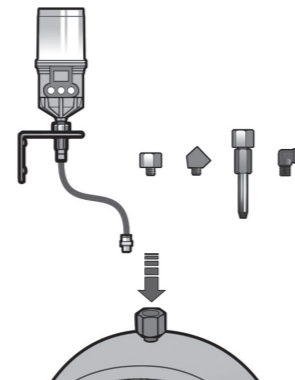

### Single Point Installation

#### Direct Mount or Remote Installation using Extension Tube

Direct mount is always preferable. For applications not allowing any direct mounts, remotely mount the unit using appropriate accessories and keep the distance from the lube point as short as possible.

For remote installation using a tube, use a Ø6 O.D. (1/4") tubing pre-filled with the same or compatible grease as the grease contained in the unit.

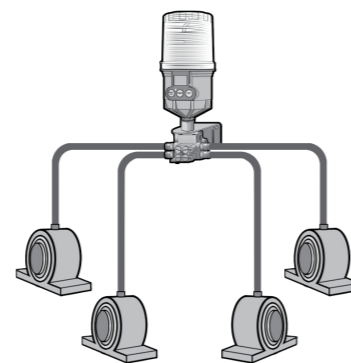

### Multi-Point Installation

#### Multi-Point Remote Installation using Progressive Divider Block (2-8 Points)

Remote multi-point lubrication is available with the Pulsarlube MSP using a divider block. It is recommended to test the back pressure of the bearing, lube lines, and divider block after assembly using a grease gun connected to a pressure gauge. Ensure the break-off pressure is below the average operating pressure of 30bar (435psi).

## Warning

- ▶ For remote installation, keep the maximum distance at 6m (20ft) or less.
- ▶ Do not plug any open ports on the divider block. The kit or divider block must be ordered with the appropriate number of points required. For more information on the divider block, please refer to the Multi-Point Remote Installation Manual.
- ▶ Use the lithium battery pack for specific applications such as: extremely cold temperature, extended period mode setting (18 & 24 months), any multi-point or long distance single point (greater than 10ft) for 500ml unit.

**Shelf life and Product Warranty** Warranty is limited to original defects in material and workmanship and will not cover any collateral damage due to mishandling, abuse and /or any other inappropriate use of this product. Warranty period is 1 year from the date of purchase.

Rev.06

# PULSARLUBE

The World Leader of Automatic Lubrication

## Pulsarlube USA, Inc.

1170 Ardmore Ave Itasca IL 60143, USA  
 TEL:1-847-593-5300 FAX:1-847-593-5303 www.pulsarlube.com / info@pulsarlube.com

PULSARLUBE

User Manual

# Pulsarlube MSP Series

(60ml/125&250ml/500ml)

